



Main

Range of product	Altivar Machine ATV340
Product or component type	Variable speed drive
Device application	Machine
Device short name	ATV340
Variant	Standard version
Product destination	Asynchronous motors Synchronous motors
Mounting mode	Wall mount
EMC filter	Integrated with 150 m motor cable maxi conforming to EN/IEC 61800-3 category C3
IP degree of protection	IP20 conforming to IEC 61800-5-1 IP20 conforming to IEC 60529
Degree of protection	UL type 1 conforming to UL 508C
Type of cooling	Forced convection
Supply frequency	50...60 Hz +/- 5 %
Network number of phases	3 phases
[Us] rated supply voltage	380...480 V - 15...10 %
Motor power kW	55 kW (normal duty) 45 kW (heavy duty)
Motor power hp	75 hp (normal duty) 60 hp (heavy duty)
Line current	97.2 A at 380 V with internal line choke (normal duty) 84.2 A at 480 V with internal line choke (normal duty) 81.4 A at 380 V with internal line choke (heavy duty) 71.8 A at 480 V with internal line choke (heavy duty)
Prospective line I _{sc}	50 kA
Apparent power	70 kVA at 480 V (normal duty) 59.7 kVA at 480 V (heavy duty)
Continuous output current	106 A at 4 kHz (normal duty) 88 A at 4 kHz (heavy duty)
Maximum transient current	132 A during 60 s (heavy duty) 127.2 A during 60 s (normal duty)

Disclaimer: This documentation is not intended as a substitute for and is not to be used for determining suitability or reliability of these products for specific user applications

	127.2 A during 2 s (normal duty) 132 A during 2 s (heavy duty)
Asynchronous motor control profile	Constant torque standard Variable torque standard Optimized torque mode
Synchronous motor control profile	Permanent magnet motor Reluctance motor
Speed drive output frequency	0.1...500 Hz
Nominal switching frequency	2.5 kHz
Switching frequency	1...8 kHz adjustable 2.5...8 kHz with derating factor
Safety function	STO (safe torque off) SIL 3

Complementary

Discrete input logic	16 preset speeds
Communication port protocol	Ethernet/IP Modbus serial Modbus TCP
Option card	Slot GP-X : digital and analog I/O extension module Slot GP-X : output relay extension module Slot GP-ENC : 5/12 V digital encoder interface module Slot GP-ENC : analog encoder interface module Slot GP-ENC : resolver encoder interface module
Output voltage	<= power supply voltage
Permissible temporary current boost	1.5 x I _n for 60 s (heavy duty) 1.2 x I _n for 60 s (normal duty)
Motor slip compensation	Adjustable Automatic whatever the load Can be suppressed Not available in permanent magnet motor law
Acceleration and deceleration ramps	S, U or customized Linear adjustable separately from 0.01...9999 s
Braking to standstill	By DC injection
Protection type	Motor: thermal protection Drive: thermal protection Drive: overheating Drive: line supply overvoltage Drive: line supply undervoltage Drive: break on the control circuit Motor: safe torque off Drive: safe torque off Drive: short-circuit between motor phases Motor: motor phase loss Drive: overcurrent Drive: output overcurrent between motor phase and earth Drive: output overcurrent between motor phases Drive: short-circuit between motor phase and earth Drive: motor phase loss Drive: DC Bus overvoltage Drive: input supply loss Drive: exceeding limit speed
Frequency resolution	Display unit: 0.1 Hz Analog input: 0.012/50 Hz
Electrical connection	Screw terminal with clamping capacity: 0.75...1.5 mm ² , AWG 18...AWG 16 on control Screw terminal with clamping capacity: 70...120 mm ² , AWG 1/0...250 kcmil on line side Screw terminal with clamping capacity: 70...120 mm ² , AWG 1/0...250 kcmil on DC bus Screw terminal with clamping capacity: 70...120 mm ² , AWG 1/0...250 kcmil on motor
Connector type	Connector(S)1 x RJ45, Modbus serial on front face Connector(S)1 x RJ45, Modbus serial for HMI on front face Connector(S)2 x RJ45, Ethernet IP/Modbus TCP on front face
Physical interface	2-wire RS 485 Modbus serial
Transmission frame	RTU Modbus serial
Transmission rate	10/100 Mbit/s Ethernet IP/Modbus TCP 4800 bps, 9600 bps, 19200 bps, 38.4 Kbps Modbus serial
Exchange mode	Half duplex, full duplex, autonegotiation Ethernet IP/Modbus TCP

Data format	8 bits, configurable odd, even or no parity Modbus serial
Type of polarization	No impedance Modbus serial
Number of addresses	1...247 Modbus serial
Method of access	Slave Modbus TCP Slave Modbus RTU
Supply	External supply for digital inputs : 24 V DC (19...30 V), <= 1.25 mA, protection type: overload and short-circuit protection Internal supply for reference potentiometer (1 to 10 kOhm) : 10.5 V DC +/- 5 %, <= 10 mA, protection type: overload and short-circuit protection Internal supply for digital inputs and STO : 24 V DC (21...27 V), <= 200 mA, protection type: overload and short-circuit protection
Local signalling	3 LED, mono/dual colour for local diagnostic 5 LED, dual colour for embedded communication status 2 LED, dual colour for communication module status 1 LED, red for presence of voltage
Width	271 mm
Height	908 mm
Depth	309 mm
Product weight	56.4 kg
Analogue input number	3
Analogue input type	AI1, AI2, AI3 software-configurable voltage : 0...10 V DC, impedance 31.5 kOhm, resolution 12 bits AI1, AI3 software-configurable current : 0...20 mA, impedance 250 Ohm, resolution 12 bits AI1, AI3 software-configurable temperature probe or water level sensor
Discrete input number	10
Discrete input type	STOA, STOB safe torque off, 24 V DC (<= 30 V), impedance > 2.2 kOhm DI7, DI8 programmable as pulse input : 0...30 kHz, 24 V DC (<= 30 V) DI1...DI8 programmable, 24 V DC (<= 30 V), impedance 4.4 kOhm
Input compatibility	STOA, STOB : discrete input level 1 PLC conforming to EN/IEC 61131-2 DI1...DI8 : discrete input level 1 PLC conforming to EN/IEC 61131-2 DI7, DI8 : pulse input level 1 PLC conforming to IEC 65A-68
Discrete input logic	STOA, STOB positive logic (source) at State 0: < 5 V, at State 1: > 11 V DI1...DI8 positive logic (source) at State 0: < 5 V, at State 1: > 11 V DI1...DI8 negative logic (sink) at State 0: > 16 V, at State 1: < 10 V DI7, DI8 positive logic (source) at State 0: < 0.6 V, at State 1: > 2.5 V
Analogue output number	2
Analogue output type	Software-configurable voltage AQ1, AQ2 : 0...10 V DC impedance 470 Ohm, resolution 10 bits Software-configurable current AQ1, AQ2 : 0...20 mA impedance 500 Ohm, resolution 10 bits
Discrete output number	2
Input/Output type	Logic output DQ- : 0...1 kHz, <= 30 V DC, 100 mA Logic output DQ+ : 0...1 kHz, <= 30 V DC, 100 mA Programmable as pulse output DQ+ : 0...30 kHz, <= 30 V DC, 20 mA
Sampling duration	Discrete input DI1...DI8 : 2 ms (+/- 0.5 ms) Pulse input DI7, DI8 : 5 ms (+/- 1 ms) Analog input AI1, AI2, AI3 : 1 ms (+/- 1 ms) Analog output AQ1, AQ2 : 5 ms (+/- 1 ms)
Accuracy	Analog input AI1, AI2, AI3 : +/- 0.6 % for a temperature variation 60 °C Analog output AQ1, AQ2 : +/- 1 % for a temperature variation 60 °C
Linearity error	AI1, AI2, AI3 : +/- 0.15 % of maximum value for analog input AQ1, AQ2 : +/- 0.2 % for analog output
Relay output number	3
Relay output type	Configurable relay logic R1 : fault relay NO/NC 100000 cycles at maximum switching current Configurable relay logic R2 : sequence relay NO 100000 cycles at maximum switching current Configurable relay logic R3 : sequence relay NO 100000 cycles at maximum switching current
Refresh time	Relay output R1, R2, R3 : 5 ms (+/- 0.5 ms)
Minimum switching current	Relay output R1, R2, R3 : 5 mA at 24 V DC
Maximum switching current	Relay output R1 : 3 A at 250 V AC on resistive load (cos phi = 1) Relay output R1 : 3 A at 30 V DC on resistive load (cos phi = 1) Relay output R1 : 2 A at 250 V AC on inductive load (cos phi = 0.4 and L/R = 7 ms) Relay output R1 : 2 A at 30 V DC on inductive load (cos phi = 0.4 and L/R = 7 ms) Relay output R2, R3 : 5 A at 250 V AC on resistive load (cos phi = 1) Relay output R2, R3 : 5 A at 30 V DC on resistive load (cos phi = 1) Relay output R2, R3 : 2 A at 250 V AC on inductive load (cos phi = 0.4 and L/R = 7 ms) Relay output R2, R3 : 2 A at 30 V DC on inductive load (cos phi = 0.4 and L/R = 7 ms)

Environment

Isolation	Between power and control terminals
Insulation resistance	> 1 mOhm 500 V DC for 1 minute to earth
Noise level	62.4 dB conforming to 86/188/EEC
Power dissipation in W	Natural convection : 105 W at 380 V, switching frequency 4 kHz (heavy duty) Forced convection : 943 W at 380 V, switching frequency 4 kHz (heavy duty) Natural convection : 115 W at 380 V, switching frequency 4 kHz (normal duty) Forced convection : 917 W at 380 V, switching frequency 4 kHz (normal duty)
Volume of cooling air	295 m3/h
Operating position	Vertical +/- 10 degree
Electromagnetic compatibility	1.2/50 µs - 8/20 µs surge immunity test level 3 conforming to IEC 61000-4-5 Electrical fast transient/burst immunity test level 4 conforming to IEC 61000-4-4 Electrostatic discharge immunity test level 3 conforming to IEC 61000-4-2 Radiated radio-frequency electromagnetic field immunity test level 3 conforming to IEC 61000-4-3 Conducted radio-frequency immunity test level 3 conforming to IEC 61000-4-6
Pollution degree	2 conforming to EN/IEC 61800-5-1
Vibration resistance	1.5 mm peak to peak (f= 2...13 Hz) conforming to IEC 60068-2-6 1 gn (f= 13...200 Hz) conforming to IEC 60068-2-6
Shock resistance	15 gn (duration = 11 ms) conforming to IEC 60068-2-27
Relative humidity	5...95 % without condensation conforming to IEC 60068-2-3
Ambient air temperature for operation	50...60 °C with current derating (heavy duty) 40...60 °C with current derating (normal duty) -15...50 °C without current derating (heavy duty) -15...40 °C without current derating (normal duty)
Ambient air temperature for storage	-40...70 °C
Operating altitude	1000...4800 m with current derating 1 % per 100 m <= 1000 m without derating
Environmental characteristic	Chemical pollution resistance class 3C3 conforming to EN/IEC 60721-3-3 Dust pollution resistance class 3S3 conforming to EN/IEC 60721-3-3
Standards	EN/IEC 61800-3 EN/IEC 61800-3 environment 1 category C2 EN/IEC 61800-3 environment 2 category C3 UL 508C EN/IEC 61800-5-1 IEC 61000-3-12 IEC 60721-3 IEC 61508 IEC 13849-1
Product certifications	CSA TÜV UL REACH
Marking	CE

Offer Sustainability

Sustainable offer status	Green Premium product
RoHS (date code: YYWW)	Compliant - since 1426 - Schneider Electric declaration of conformity Schneider Electric declaration of conformity
REACH	Reference not containing SVHC above the threshold Reference not containing SVHC above the threshold
Product environmental profile	Available Product Environmental Profile
Product end of life instructions	Available

Dimensions

Views: Front - Left - Rear

mm
in

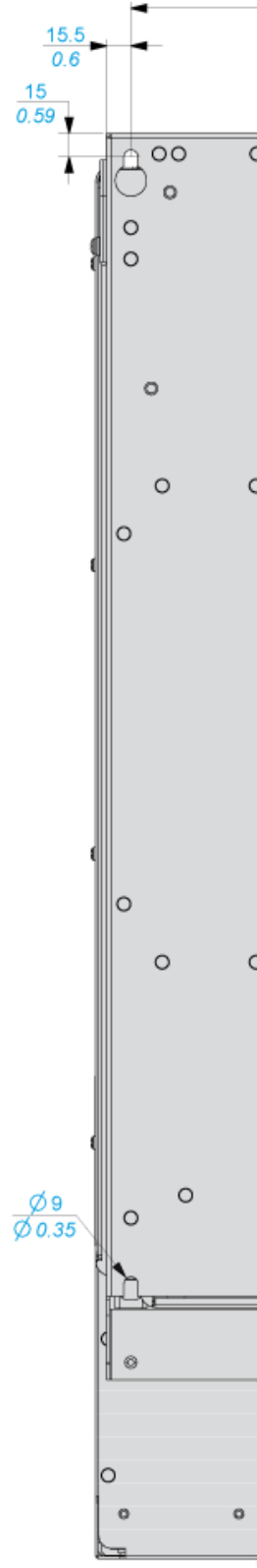
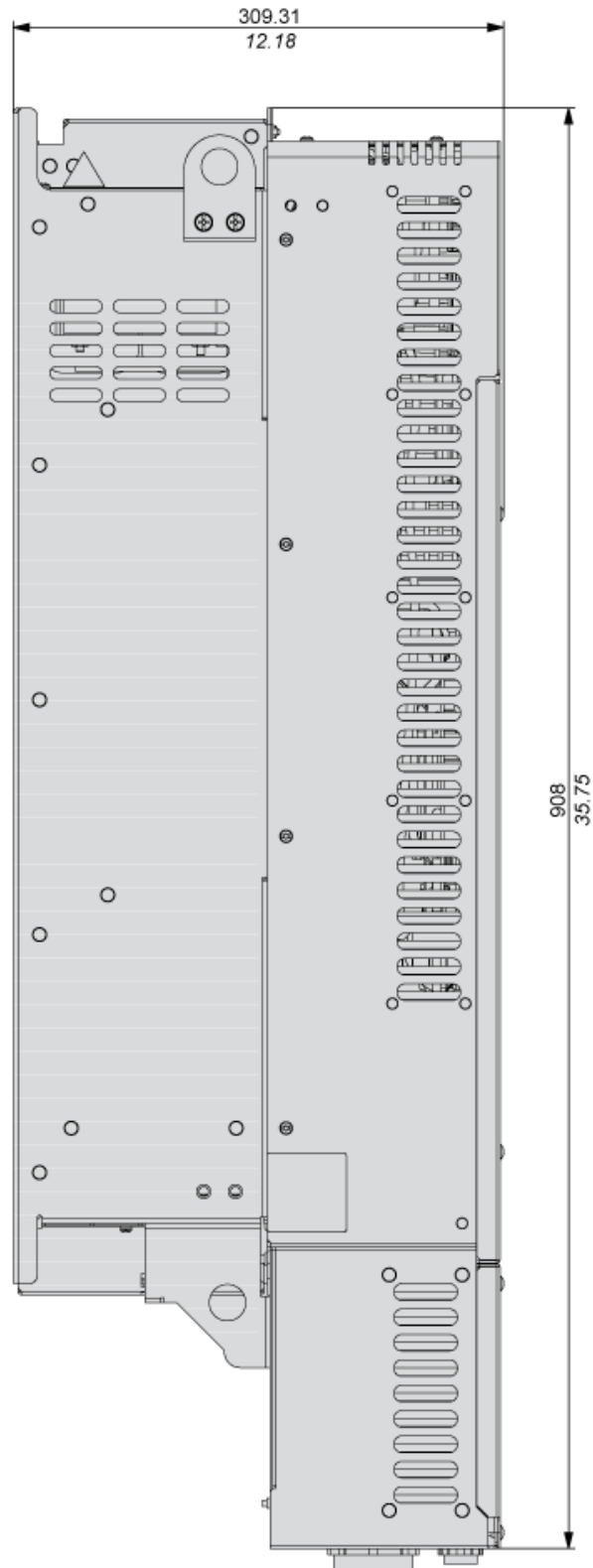
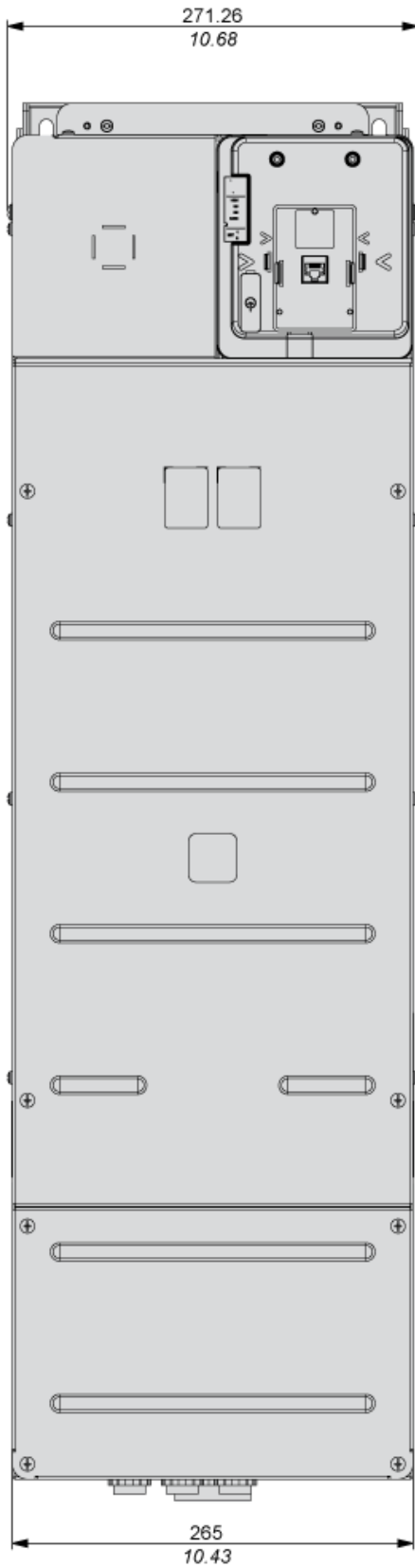

Clearance

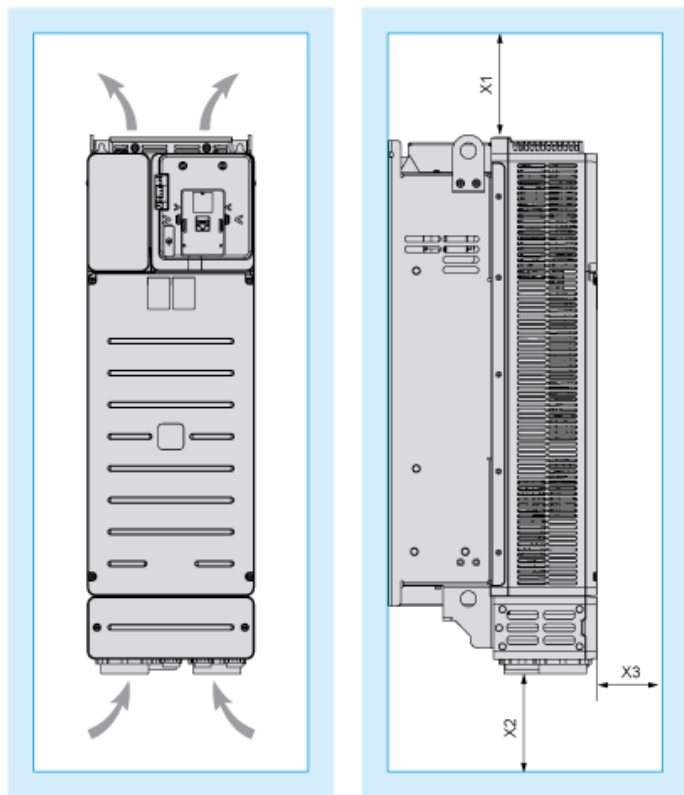

Dimensions in mm

X1	X2	X3
100	100	10

Dimensions in in.

X1	X2	X3
3.94	3.94	0.39

Mounting Types

Mounting Type A: Side by Side IP20

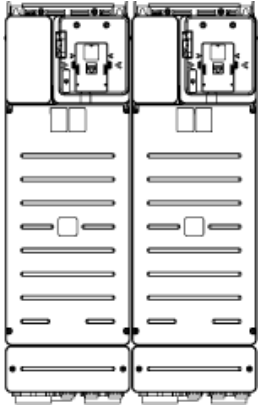

Possible, up to 50 °C, 2 drives only

Mounting Type B: Individual IP20

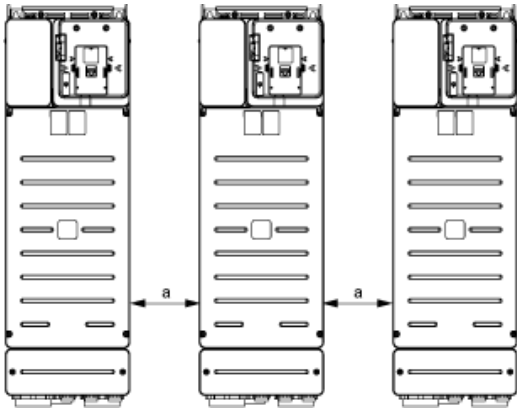

a 110 mm (4.33 in.)

Connections and Schema

Three-Phase Power Supply with Upstream Breaking via Line Contactor Without Safety Function STO

Connection diagrams conforming to standards ISO13849 category 1 and IEC/EN 61508 capacitySIL1, stopping category 0 in accordance with standard IEC/EN 60204-1.

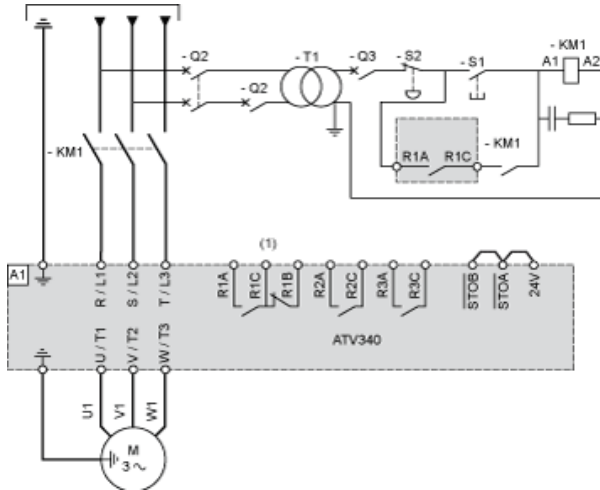

- (1) Use relay output R1 set to operating state Fault to switch Off the product once an error is detected.
A1 : Drive
KM1 : Line Contactor
Q2, Q3 : Circuit breakers
S1 : Pushbutton
S2 : Emergency stop
T1 : Transformer for control part

Three-Phase Power Supply with Downstream Breaking via Switch Disconnector

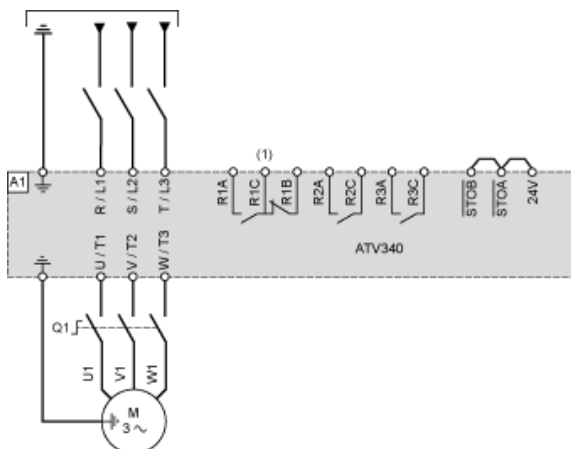

- (1) Use relay output R1 set to operating state Fault to switch Off the product once an error is detected.
A1 : Drive
Q1 : Switch disconnector

Sensor Connection

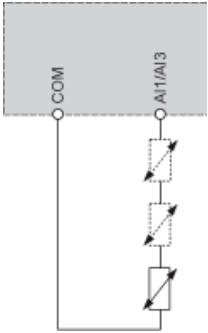

It is possible to connect either 1 or 3 sensors on terminals AI1/AI3.

Control Block Wiring Diagram

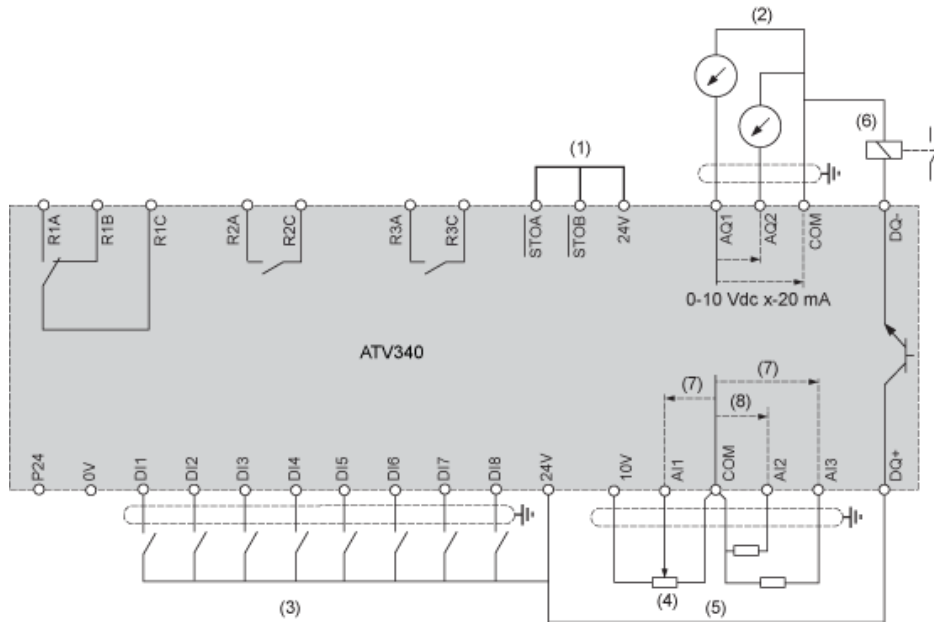

- (1) Safe Torque Off
 - (2) Analog Output
 - (3) Digital Input
 - (4) Reference potentiometer
 - (5) Analog Input
 - (6) Digital Output
 - (7) 0-10 Vdc, x-20 mA
 - (8) 0-10 Vdc, -10 Vdc...+10 Vdc
- A1 : ATV340 Drive
R1A, R1B Fault relay
R2A, R2C Sequence relay
R3A, R3C Sequence relay

Digital Inputs Wiring

Switch Set to SRC (Source) Position Using the Output Power Supply for the Digital Inputs

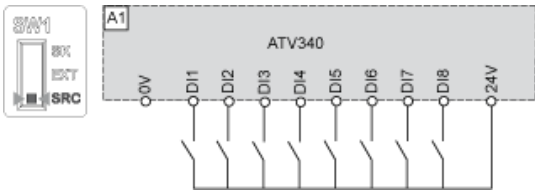

Switch Set to SRC (Source) Position and Use of an External Power Supply for the DIs

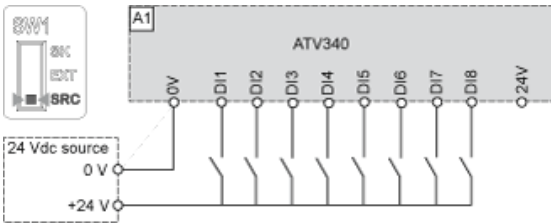

Switch Set to SK (Sink) Position Using the Output Power Supply for the Digital Inputs

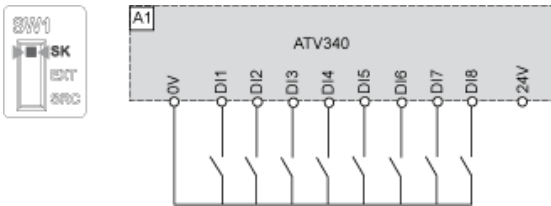

Switch Set to EXT Position Using an External Power Supply for the DIs

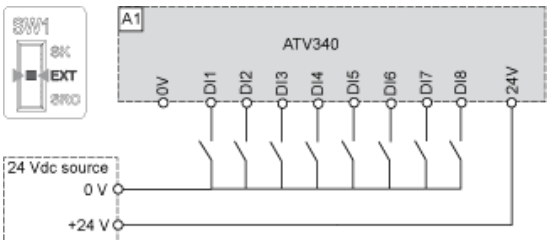

Digital Outputs Wiring

Digital Outputs: Internal Supply

Positive Logic, Source, European Style, DQ switches to +24V



(1) Relay or valve

Negative Logic, Sink, Asian Style, DQ switches to 0V

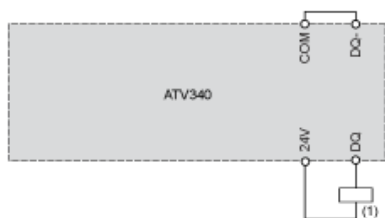

(1) Relay or valve

Digital Outputs: External Supply

Positive Logic, Source, European Style, DQ switches to +24V

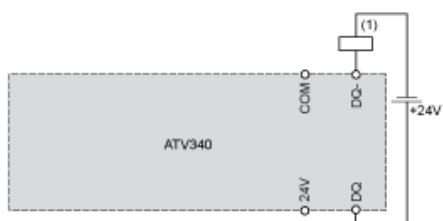

(1) Relay or valve

Negative Logic, Sink, Asian Style, DQ switches to 0V

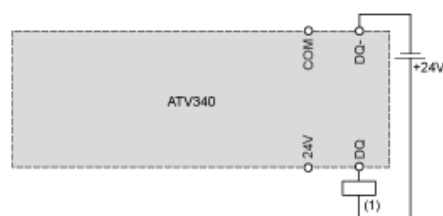

(1) Relay or valve

Derating Curves

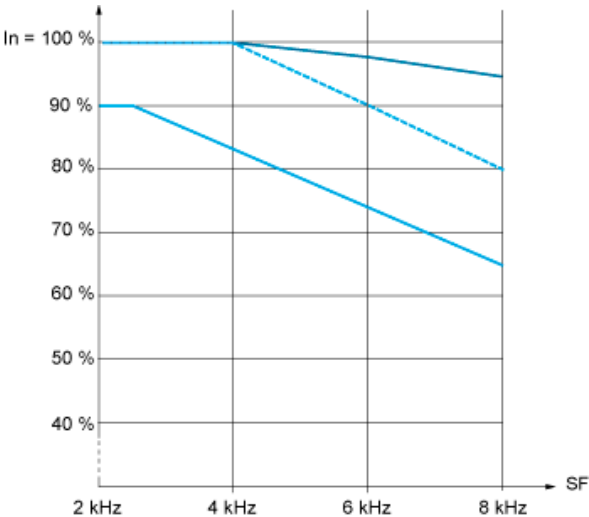

- 40 °C (104 °F) - Mounting type A and B
 - - - 50 °C (122 °F) - Mounting type A and B
 - 60 °C (140 °F) - Mounting type B
- In : Nominal Drive Current
SF : Switching Frequency